

STEPPED COUPLING

NO.	PART NAME	MATERIAL
1	Sleeve	DUCTILE IRON
2	End ring	DUCTILE IRON
3	Gasket	EPDM/SBR
4	Bolt, Nut	Carbon Steel

NOTE: WORKING PRESSURE PN10、PN16

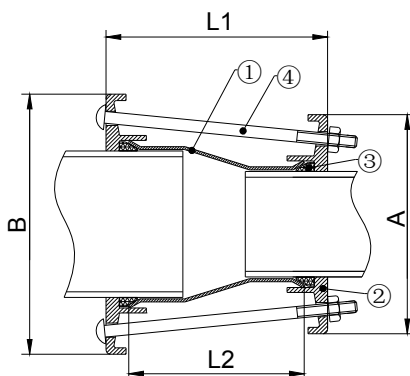

mm

SIZE RANGE				A	B	L1	L2	BOLT NO.xDiax Length
SMALL END		LARGE END						
MIN	MAX	MIN	MAX					
59	72	63	84	154.5	173.5	210	110	4-M12x200
59	72	84	103	154.5	195.5	210	110	4-M12x200
63	84	84	103	173.5	195.5	210	110	4-M12x200
88	103	103	132	195.5	224.5	210	110	4-M12x200
108	128	132	158	224.5	254.5	220	120	4-M12x210
132	158	158	182	254.5	280.5	220	120	4-M12x210
158	182	192	210	280.5	306.5	230	130	4-M12x220
192	210	218	235	306.5	342.5	230	130	4-M12x220
218	235	242	266	342.5	367.5	230	130	6-M12x220
242	266	272	289	367.5	399.5	230	130	6-M12x220